

Side Pressure Tensimeter

- SPT-104-500K
- SPT-104-1T
- SPT-104-2T
- SPT-104-5T
- SPT-104-10T

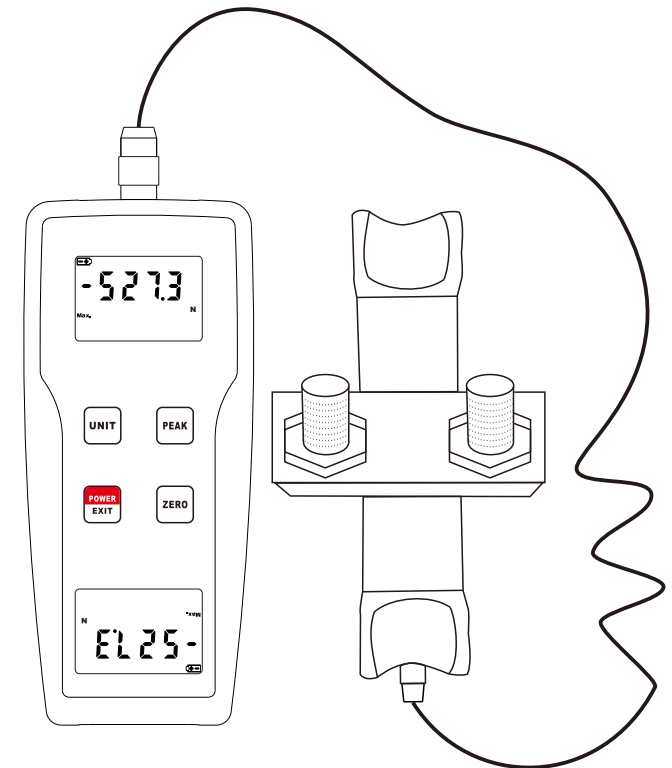

When you purchase this Side Pressure Tensimeter, you mark a step forward in the field of precision measurement. This table is a computer - based testing tool, which can be used for many years if handled properly. Before use, please read this manual carefully and keep it in an accessible place.

CONTENT

1. INTRODUCTIONS1

2. FUNCTIONS AND FEATURES1

3. TECHNICAL PARAMETERS2

4. STRUCTURE DESCRIPTION3

 4.1 Overall Structure3

 4.2 Display4

 4.3 Operation Key5

5. POWER ON & POWER OFF5

 5.1 Power On5

 5.2 Power Off5

6. CALIBRATION5

7. REAL TIME MEASUREMENT MODE & PEAK HOLD MODE
.....6

8. UNIT CONVERSION FUNCTION6

9. SETTING OF AUTO POWER OFF6

10. INSTALLATION & MEASUREMENT6

11. BATTERY REPLACEMENT7

12. SECURITY AND CAUTIONS7

 12.1 Cautions7

 12.2 Warning8

 12.3 Security Items8

13. ACCESSORIES9

13. ACCESSORIES

Standard Accessories	Digital Force Gauge
	Manual
	Carrying Case
Optional Accessories	Power Adapter

10.4 If the gauge is not to be used for any extended period, remove batteries.

11. SECURITY AND CAUTIONS

11.1 Cautions

- A. If the operation is incorrect, it is possible to damage the gauge or cause serious accident. In the manual, the important items of accident prevention and measurement procedure of the gauge are pointed out. Please read this manual carefully before measurement, keep it properly after reading, in preparation to read again.
- B. If it is to test the impact load, please select models with safe load at least double as large as the impact load.

12.2 Warning

- A. In destructive testing, protective masks and gloves should be worn to prevent the occurrence of the damage to the human body because of material splashing during testing.
- B. Do not use fixtures which have been damaged or severely bent. For users, please refer to the relevant specifications in this manual when using a self-made fixture (various types of fixtures are provided for customers to select according to need).
- C. Do not test force exceeding the maximum range of the gauge. Otherwise it may cause damage to the sensor, or even an accident.
- D. When the tested force exceeds 110% of the range, a continuous buzzer alarm comes out. In this case, please remove the load quickly, or reduce the load.

12.3 Security Items

- A. When using the power adapter, the voltage of power supply should be the same as the rated voltage, or it may cause electric shock or fire.
- B. Do not pull out or insert the plug with wet hands, or it may lead to electric shock.
- C. Don't pull the cable of the power adapter to pull the plug, to avoid wire broken and electric shocks.
- D. Please use a soft cloth to clean the gauge. Soak the cloth in the water with cleaning agent, wring it out, and then use it to remove the dust and dirt.
Note: do not use volatile chemicals to clean the gauge (such as volatile agents, thinner, alcohol, etc.)
- E. Do not use the gauge in the following environment,
 - 1. Wet environment
 - 2. Dusty environment
 - 3. The place where with the use of chemicals or oil
 - 4. The place where with vibration source

1. INTRODUCTIONS

SPT-104 series side pressure tensimeter is a digital display tensimeter designed and developed by our company. It has the advantages of high precision, easy operation and convenient carrying. More peak holding test mode, convenient for testers to use, all kinds of test bench and fixture combination can constitute different uses of testing machine. There are many specifications for the user to choose, the user can be tested according to the required product force value size, select the corresponding specifications of the instrument. Scientific use of the test range is 10% to 100% of the full range, the metrology department recommended not to use less than 1% of the full range. At the same time, after the instrument and the object to be tested are in place before the test, press the ZERO (ZERO) key to clear the ZERO to eliminate the weight of the fixture. Side pressure tension tester is a special instrument for measuring the tension of wind tower, signal transmission tower, power transmission system and other ropes. It is easy to operate and carry. More has a variety of testing modes, convenient for testers to use,

2. FUNCTIONS AND FEATURES

- * High accuracy and high resolution.
- * Digital display with no guessing or errors.
- * With 4 measurement unit for selection and conversion, N, kg, lb.
- * With peak value hold function.
- * Power can be supplied by either alkaline battery or 5V DC power.

3. TECHNICAL PARAMETERS

Model	SPT-104-500K	SPT-104-1T	SPT-104-2T	SPT-104-5T	SPT-104-10T
Force Range	±500kgf	±1000kgf	±2000kgf	±5000kgf	±10000kgf
	±4900N	±9800N	±16900N	±49000N	±98000N
	±1100Lbf	±2200Lbf	±4400Lbf	±11000Lbf	±22000Lbf
Resolution	0.01kgf (<100kgf) 0.1kgf (≥100kgf)	0.01kgf (<100kgf) 0.1kgf (≥100kgf)	0.01kgf (<100kgf) 0.1kgf (≥100kgf)	0.01kgf (<100kgf) 0.1kgf (≥100kgf)	0.01kgf (<100kgf) 0.1kgf (≥100kgf)
	0.1N (<1000N) 1N (≥1000N)	0.1N (<1000N) 1N (≥1000N)	0.1N (<1000N) 1N (≥1000N)	0.1N (<1000N) 1N (≥1000N)	0.1N (<1000N) 1N (≥1000N)
	0.1Lbf (<1000Lbf) 1Lbf (≥1000Lbf)	0.1Lbf (<1000Lbf) 1Lbf (≥1000Lbf)	0.1Lbf (<1000Lbf) 1Lbf (≥1000Lbf)	0.1Lbf (<1000Lbf) 1Lbf (≥1000Lbf)	0.1Lbf (<1000Lbf) 1Lbf (≥1000Lbf)
Accuracy	± 0.5%FS ± 1Digit				
Unit	kgf, N, Lbf				
Measurement State	Peak Value Measurement, Real Time Measurement				
Display	2 Reversed 4 Digit Lcd				
Power Off	10 Minutes Auto Power Off, Manual Power Off				
Backlight	Blue Backlight				
Safe Load	150%FS (Buzzer Alarm Over 110%FS)				
Power Supply	2x1.5 AA(UM-3) Battery or 5V DC Power Supply				
Operating Conditions	Temperature: 0°C~40°C				
	Humidity: <80%				
Surrounding	No Vibration Source or Corrosive Medium Around				
Weight	1165g				
Case Size	175mmx80mmx36mm				
Sensor Size	140mmx65mmx105mm				

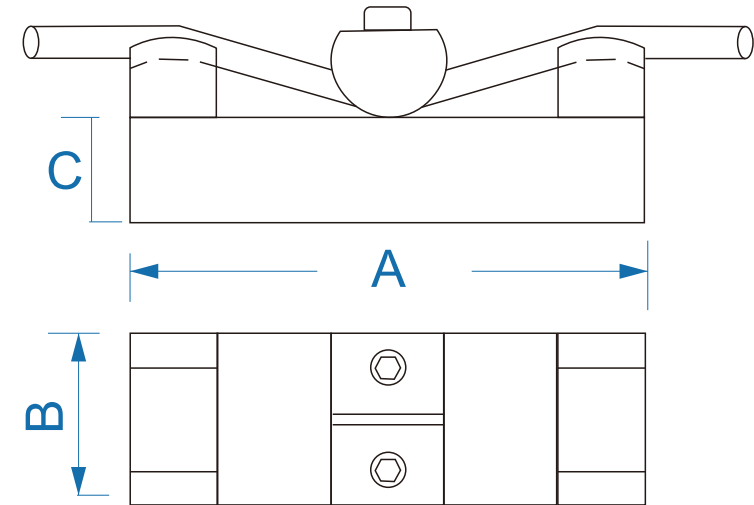

Wire rope tension	Wire rope diameter	A	B	C
500KG	6MM-26MM	140MM	30MM	32MM
1T				
2T				
5T				
10T				

10. BATTERY REPLACEMENT

10.1 When it is necessary to replace the battery, the battery symbol will appear on the Display.

10.2 Slide the Battery Cover away from the gauge and remove the batteries.

10.3 Install new batteries correctly into the case.

* When the weight of the used fixture is more than 20% of the range, or the load of the gauge is more than 20% of the range, the gauge is not able to be calibrated. In this case, it is necessary to use a lighter fixture or remove the load, then calibrate.

7. REAL TIME MEASUREMENT MODE & PEAK HOLD MODE

Two kinds of measurement modes can be set for this gauge, the Real Time Measurement Mode and the Peak Hold Mode.

When there is no peak indicator "MAX" on the display, it is in the Real Time Measurement Mode. The displayed test value changes according to the load.

Press the Peak Value Key (PEAK), the peak indicator "MAX" comes out on the display. It is in the Peak Hold Mode. The displayed test value is the maximum value during the measurement.

8. UNIT CONVERSION FUNCTION

In either Real Time Measurement Mode or Peak Hold Measurement Mode, press the Unit Key (UNIT) for measurement unit conversions.

9. INSTALLATION & MEASUREMENT

Power on the gauge, press operation keys to select the intended measurement mode according to the need, or measure directly with the factory default settings.

- A. Select appropriate test fixtures to install on the sensor (to use self-made fixtures, please refer to the relevant datas on the next page 'Shape And Installation Dimensions').
- B. When measuring, please hold the sensor firmly or install it on a suitable test machine. Please make the force and the central axis of sensor in a straight line, so that measurements of load are accurate.
- C. After the measuring, remove the load, turn off the gauge, remove the fixtures, and then put the items back in the tool box after cleaning, in order to prepare for the next use.

4. STRUCTURE DESCRIPTION

4.1 Overall Structure

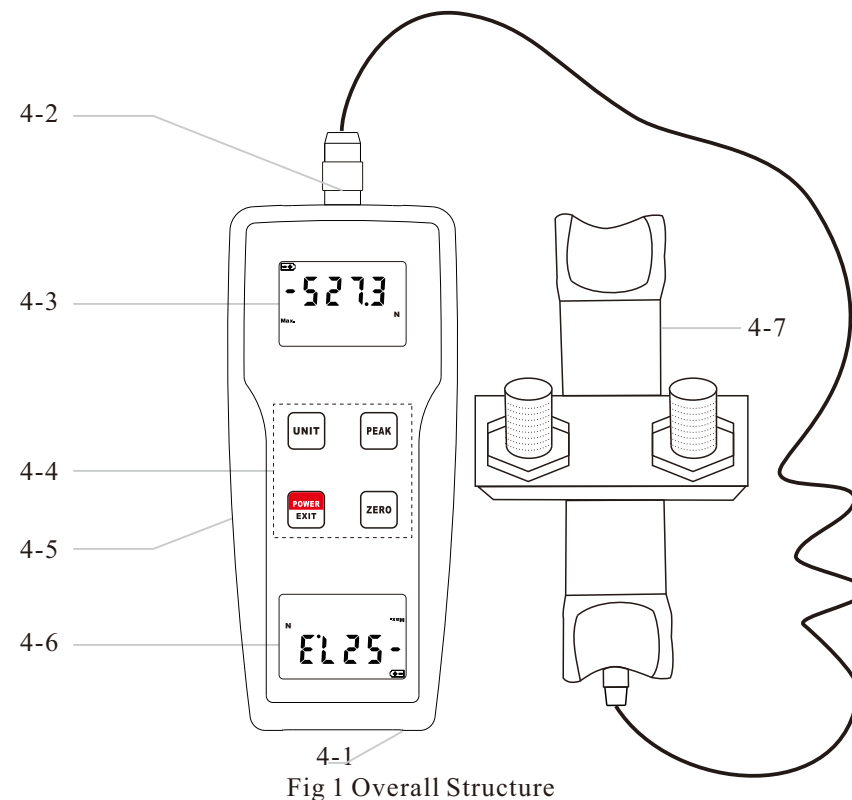

Fig 1 Overall Structure

Function Description Of Overall Structure

4-1 Power Interface

It can be connected with 5V DC Power for power supply.

4-2 Sensor Plug

It is used to connect main unit and sensor.

4-3 Display A

It is used to display the readings of measurement, units of measurement, the indications of the operation, etc.

4-4 Operation Key Area

All operation keys are distributed on this area. Thus, all keys of the gauge can be found here.

4-5 Battery Case On The Back

The place to install batteries, for battery supply.

4-6 Display B

It is also used to display the readings of measurement, units of measurement, the indications of the operation, etc. It is designed for more convenient reading on multiple directions.

4-7 Sensor

It is used to convert the received force information into electrical signals to main unit.

4.2 Display

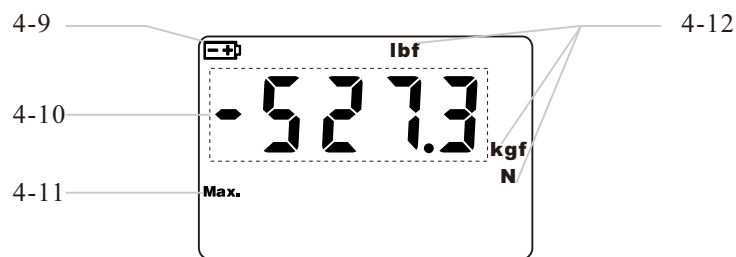



Fig 2 Display

Function Description Of Display

4-9 Battery Indicator ‘’

When the battery voltage is low, ‘’ comes on the top left corner of the display, indicating it is lack of voltage and the batteries need to be replaced.

4-10 Displayed Reading

In this gauge, the pushing force is a positive value (not shown "+"); the pulling force is a negative value (display "-").

4-11 Peak Value Indicator MAX.

When the indicator ‘MAX.’ comes, it indicates that it is in Peak Value Hold Mode, in which the displayed reading is the peak value during measurement. When the indicator ‘MAX.’ does not come, it indicates that it is in Real Time Measurement Mode, in which the displayed reading changes according with the applied load.

4-12 Measurement Unit

It indicates the current measurement unit, which includes ‘kgf’, ‘gf’, ‘N’, ‘lbf’.

4.3 Operation Key

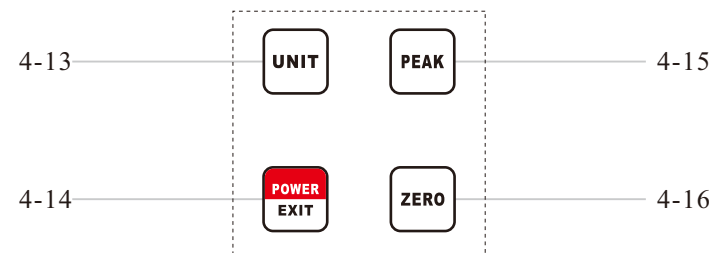

Fig.3 Operation Key

Function Description Of Operation Key

4-13 Unit Conversion Key(UNIT)

It is the key for unit conversion.

4-14 Power/Exit Key(POWER/EXIT)

It is the key for powering on/off the gauge. Also, it is the key for exiting from Data Scanning Mode. What’s more, it is the key for going into the Auto Power Off Settings.

4-15 Peak Value Key(PEAK)

It is the key for conversion between the Peak Value Hold Mode and the Real Time Measurement Mode.

4-16 Zero Key(ZERO)

It is the key for zero calibration of the gauge.

5. POWER ON & POWER OFF

5.1 Power On

Install the batteries correctly or plug in the DC power supply. Then press the Power/Exit Key(POWER/EXIT) to power on the gauge.

5.2 Power Off

5.2.1 Manual Power Off

In the state of power-on, press and hold the Power/Exit Key (POWER/EXIT) for about 2 seconds, the indicator ‘’ comes out. Then release the key, the gauge is powered off.

5.2.2 Auto Power Off

Auto power off function can be activated by user. When it is activated, the gauge will be powered off automatically after 10 minutes with no key operation. For details, please refer to 15 Setting Auto Power Off.

6. CALIBRATION

Install the gauge at the position of measurement according to the requirements. Then press the Zero Key (ZERO) to calibrate the gauge, the value of 0 comes out on the display.